

Compress 3000



Product Benefits

- Highly efficient heat pump – reduces energy by up to 65%*
- Eligible for generous government rebates***
- Smart Controls to take advantage of:
 - Cheaper overnight power prices
 - PV Solar energy generation systems
 - Noise reduction mode
- Designed for easy and low-cost installation and servicing
- The heat pump operates from -7°C to +40°C, delivering energy efficient hot water even in colder climates
- A water softening device is recommended for hard water applications

Specifications	Model	
	Unit	270L
Part Number	7736501960	
Code for REC Registry (STCs)	HP 270-2E 0 F00VIS	
Technical features		
HeatPump operating temperatures	°C	-7 to 40
Complete appliance operating temperatures	°C	-10 to 40
Outlet Water Temperature	°C	37 to 65
Outlet water set temperature range	°C	37 to 60
Storage capacity (L)	L	270
Hot water delivery at 40°C	L	335 ± 20
Max water relief pressure	kPa	1000
Max water relief pressure	kPa	800
COP**		3.3
Heat Pump Module		
Max power input	kW	0.6
Max current	A	2.6
Heat pump heating capacity	kW	1.5
Back Up Electric Element		
Maximum power input	kW	1.65
Total maximum current	A	7.2
Appliance Total		
Maximum heating capacity	kW	3.15
Maximum power input	kW	2.25
Maximum current	A	9.8
Product Dimensions		
Net empty weight	kg	130
Refrigeratiuon type / mass	kg	R134a / 0.375
Domestic Warranty		
Parts & Labour	Years	2
Tank (part only)	Years	5

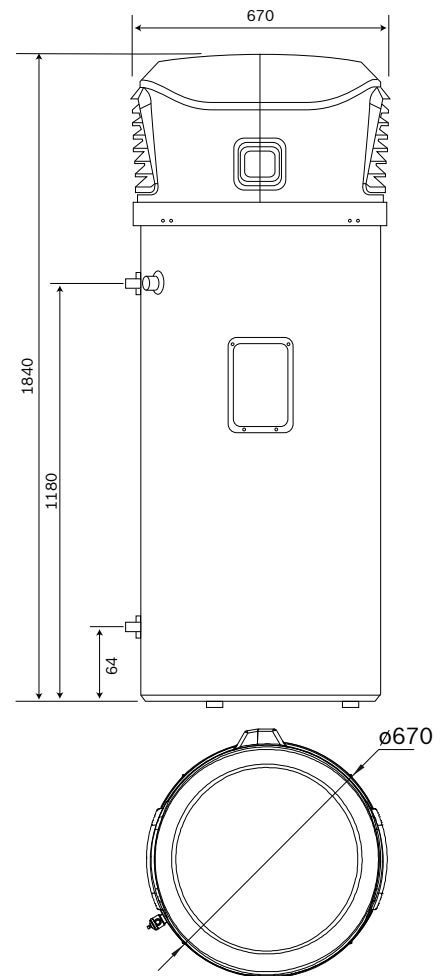

Note: Heat pumps use the ambient temperature in surrounding air to heat water in the tank. This means as the air temperature around the tank decreases, the time taken to heat the full tank increases. Customers in colder climates and frost prone areas should consider this when deciding which type of Bosch system is best for their circumstances.

* When compared with a conventional electric storage system.

** COP as measured under the following conditions:
air 15°C; RH 70%; water 15°C-60°C.

*** Postcodes for each of the STC zones are available on: ret.cleanenergyregulator.gov.au

Clearances

Heatpumps draw heat from the air surrounding the appliance. For this reason they must have sufficient clearance on both sides (at least 400mm) to allow air to pass through the appliance. Bosch also recommends that the a clearance of at least 50mm from the wall, and 600mm above the appliance is allowed so that components are easily accessible for servicing.

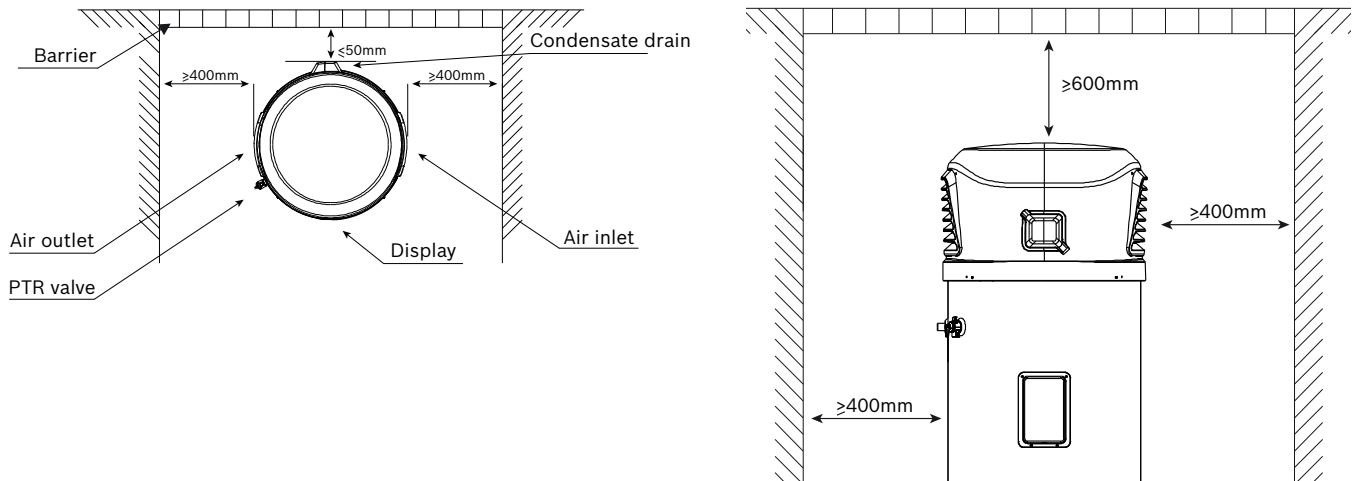

Heat pump module purge

During installation the water loop in the heat pump module must be purged to expel possible air locks. This process should be followed once the appliance has been connected to water lines and electricity, and the heat pumps tank has been filled.

- Step 1** Turn the appliance on at the electrical isolating switch. Program the date and time into the appliance.
- Step 2** Rotate the circulation pump speed selector to position "III".
- Step 3** Make sure that appliance is in Manual (man) mode. Activate the Purge (Purg) function in the appliance controls. Press the "menu" button then use the '+', '-' and 'ok' buttons to select the Purge function using the following pathway: select "Set" -> select "Purg". -> select "OK"
- Step 4** Open the brass bleed valve at the top of the water-loop inside the module (see fig 1) and allow water and bubbles to escape. Leave open for 30 to 60 seconds.
- Step 5** When no air bubbles are visible in the stream, close the brass bleed valve.
- Step 6** Open the purge screw on the side of the circulation pump (see fig 2) and leave open until water drains uniformly without air bubbles. Close the purge screw.
- Step 7** The Purge mode will continue to run for 5 mins. When complete, return the pump speed selector to position "I".

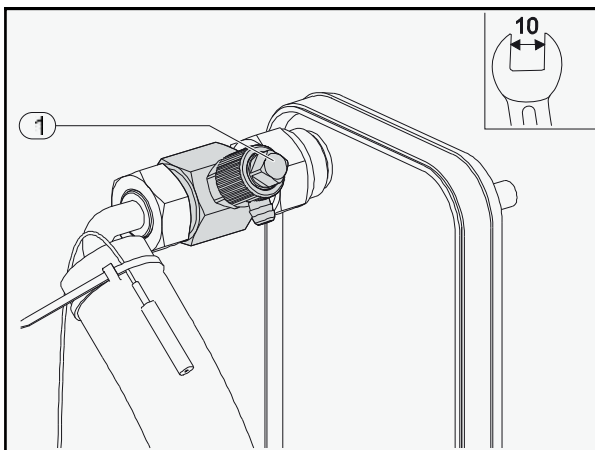

Figure 1

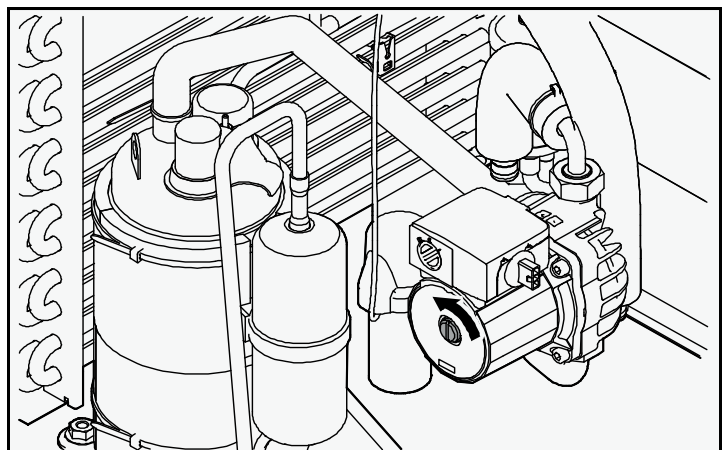

Figure 2