

FLO ARMCHAIR



With a beautiful simple solid timber frame, the armchair has a sturdy feel yet has a very light profile and footprint. Well studied proportions made it an extremely comfortable chair.

Its fully integrated back and foam seat cushions make it a very low maintenance chair. Perfect for any residential or commercial projects.

OPTIONS:

Custom timber & finishes are available. Please contact us for details.

MATERIALS & FINISHES:

Frame in solid American oak in below finishes
Upholstery: high resilience and luxura foams.
A range of fabric and leather upholstery is available

Solid American oak with satin lacquer:



Almost Black Espresso Hazelnut Clear

DIMENSIONS:

Armchair

W:710 x W:600 x H:740mm

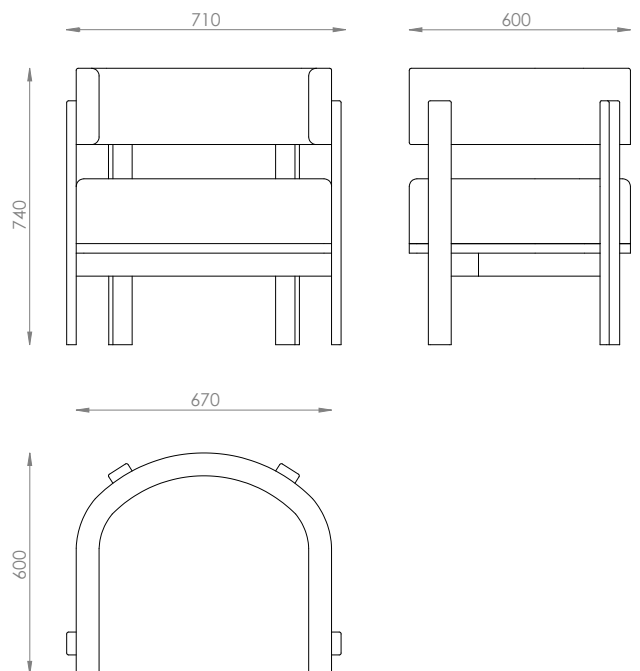

FLO ARMCHAIR

FABRIC SELECTION

AUGUSTUS

Composition: 70% wool, 25% polyamide, 5% Acrylic



Linen



Wolf

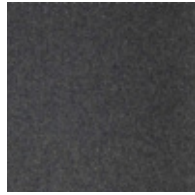

Armour

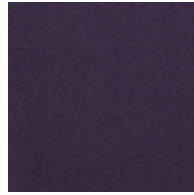

Eggplant

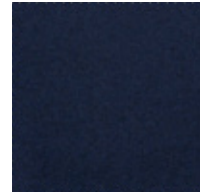

Midnight



Marshmallow



Glacier



Amazon

HUSK

Composition: 37% viscose, 24% polyester, 21% cotton, 18% linen



Ice

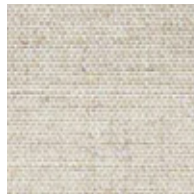

Cloud



Cement



Steel



Amalfi



Ocean



Polo



Atoll



Orchid



Amalfi

VELVET

Composition: 92% Polyester, 5% Cotton, 3% Latex.



Himalayan

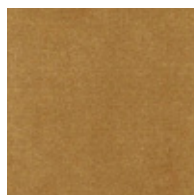

Decadent



Minx



Dreamy



Quartz



Runway

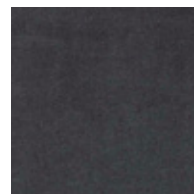

Zen



Palm

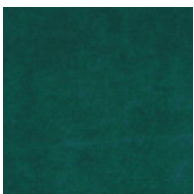

Impress

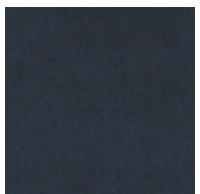

Oxford

** Custom fabrics or COM (customer's own materials) are available to trade only.

FLO ARMCHAIR

FABRIC SELECTION

HERRINGBONE

Composition: 68% linen, 26% wool, 6% Viscose



Quartz



Pepper



Charcoal



Glacier

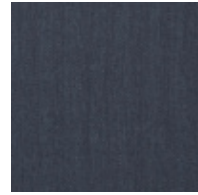

Indigo



Riverstone

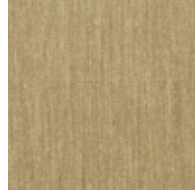

Jute

NATURE

Composition: 80% wool, 20% polyamide



Frost Grey



Pirate Black

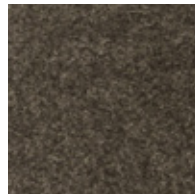

Ebony



Ashley Blue

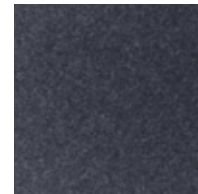

Insignia Blue



Laurel Wreath



Wheat

CALIBRE

Composition: 82% Australian wool, 18% nylon



Distinction

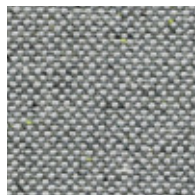

Integrity

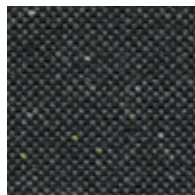

Elite

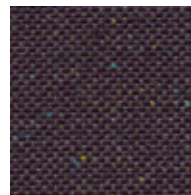

Grade

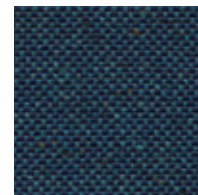

Icon

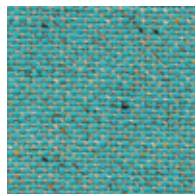

Virtue

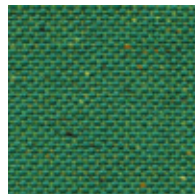

Fine

** Custom fabrics or COM (customer's own materials) are available to trade only.

FLO ARMCHAIR

LEATHER SELECTION

LEATHER ANTICO

Type: A wax aniline leather with a luxurious and supple feel which will soften with age. Source: Italy



Torrone

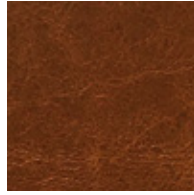

Sella

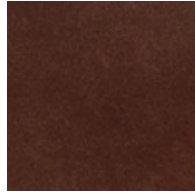

Crosta

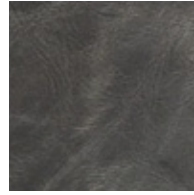

Fumo

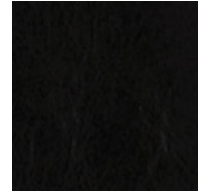

Nero

LEATHER BRUSIO

Type: Aniline leather with a distinctive matt appearance with a beeswax finish. Source: Italy



Cashew

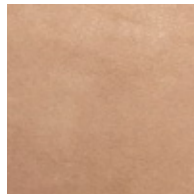

Desert



Walnut

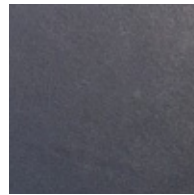

Deep Ocean

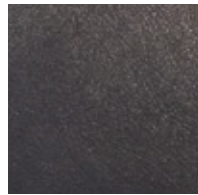

Nero

** Custom fabrics or COM (customer's own materials) are available to trade only.